

OneLab Experiences Deploying a Public PlanetLab

Timur Friedman

Assistant Professor, UPMC Paris Universitas
Scientific Director, OneLab2 Project



Outline

- OneLab and federation
- Federating PlanetLabs
- Experiences with running a public PlanetLab



The OneLab vision

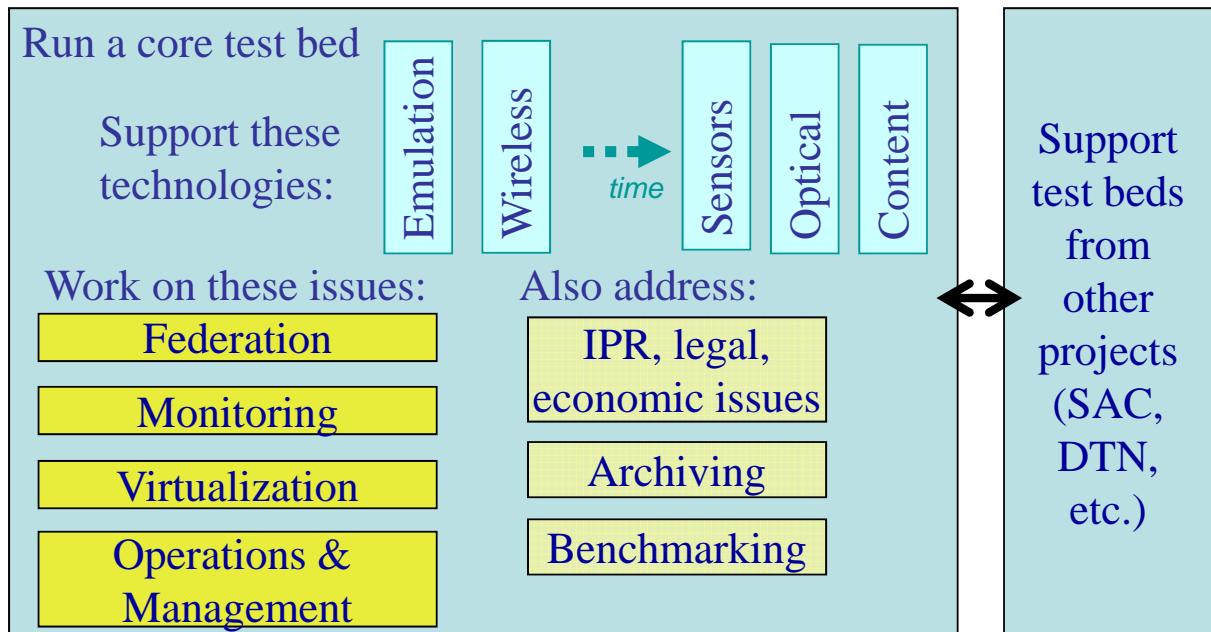

The OneLab projects

	<u>Dates</u>	<u>Partners</u> (academic & industrial)	<u>Funding</u> from EU's FIRE unit
OneLab	Sept. 2006 - Aug. 2008	10	1.9 M€
OneLab2	Sept. 2008 - Dec. 2010	26	6.3 M€

Federating test beds

Like-to-like

- Federating PlanetLab test beds

Heterogeneous testing facilities

- Wireless test beds
- Content-driven networks (CDNs)
- Situated and autonomic communications (SAC)



5

Core test bed: PlanetLab

Today's most widely-used networking test bed

- 870 nodes at 460 sites world wide

Open to the internet, many potential users of services

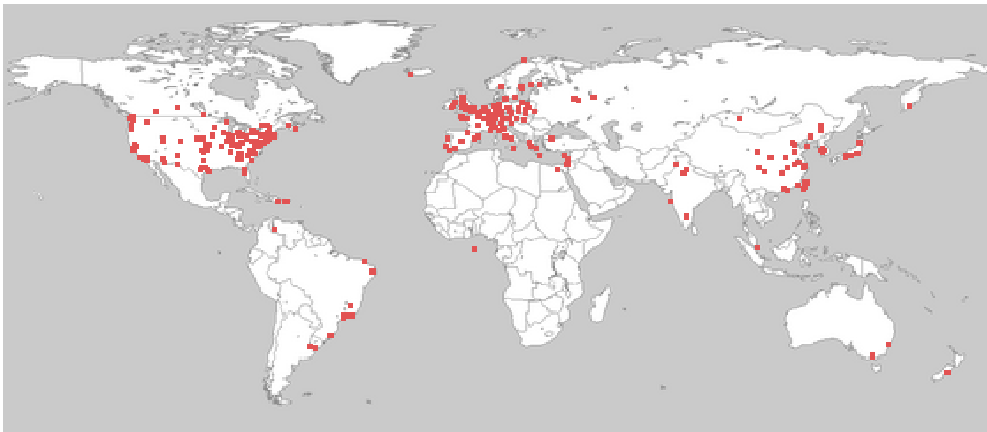

map courtesy of Princeton

6

Before OneLab

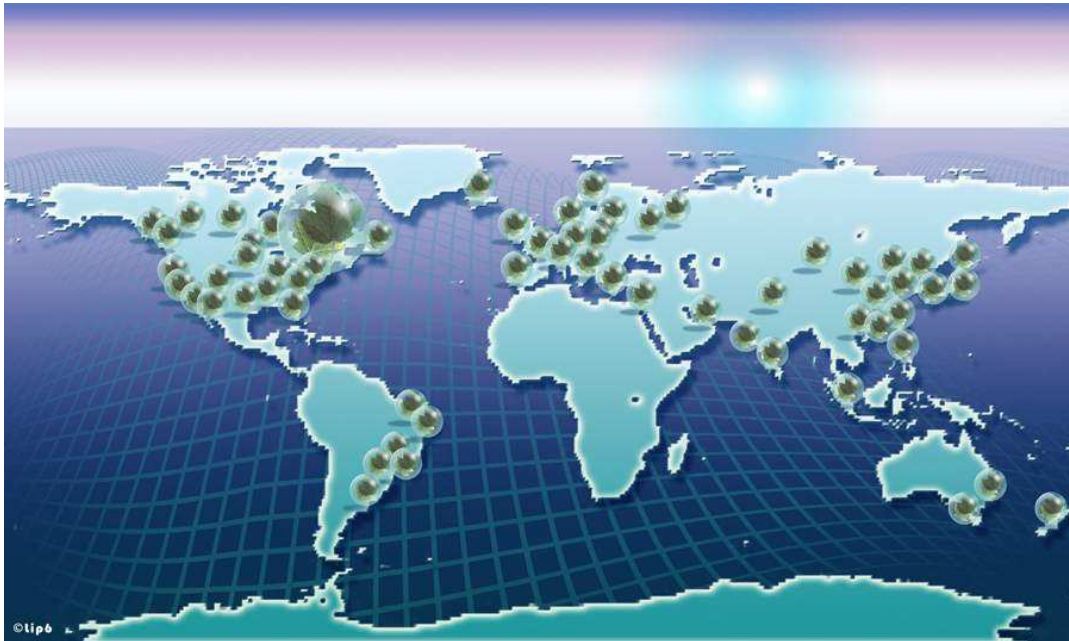

a homogeneous system

7

OneLab federation



a heterogeneous set of systems

8

Federation advantages

- Each authority deploys and manages its own nodes, welcomes its own member sites:
 - more manageable
 - more flexible policies
- An experimenter at one member site can run an experiment across the entire system:
 - large scale
- Each authority has freedom to innovative
 - but must respect a common API



9

OneLab2 federation plans

Extend PlanetLab federation

- New peer authorities
 - Korea, Japan and China?
 - *OneLab strongly supports this goal*
- New subsidiary authorities
 - National PlanetLabs within Europe
 - Private PlanetLabs (projects, corporations)

Federate with other advanced networking test beds



10

Outline

- OneLab
- Federating PlanetLabs
- Experiences with running a public PlanetLab



11

Connecting users to nodes

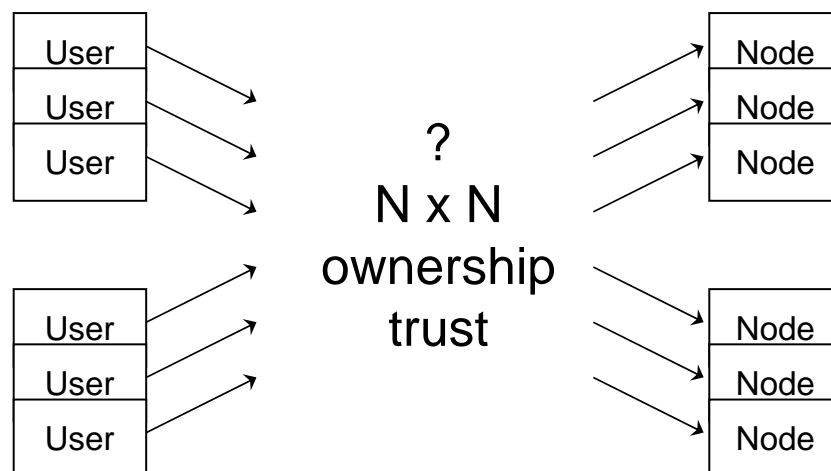

based on slide courtesy of Princeton 12

Contribution of PlanetLab

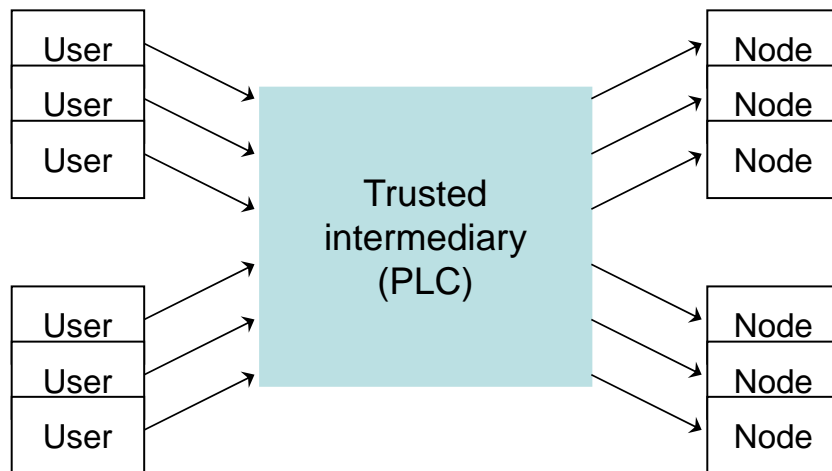

based on slide courtesy of Princeton 13

Trust problem in a federation

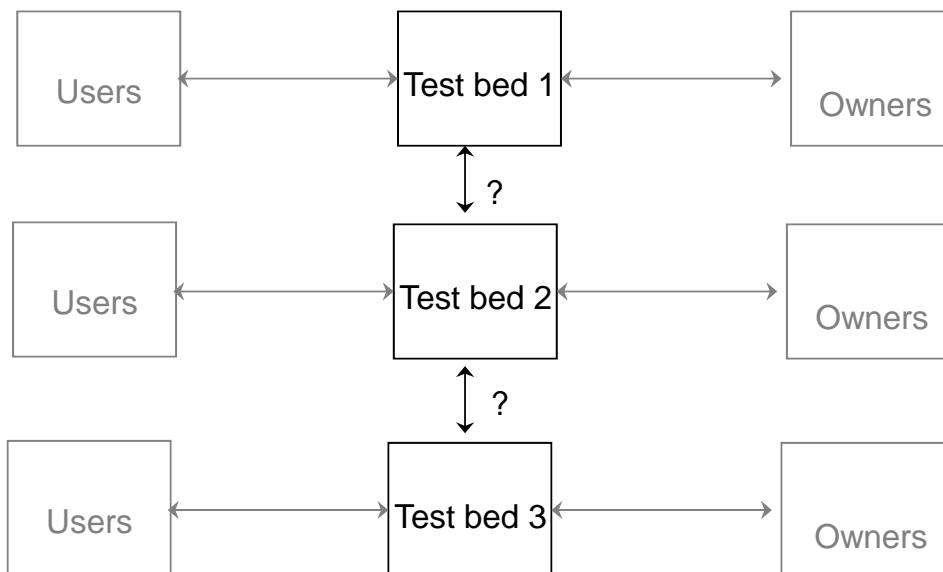

based on slide courtesy of Princeton 14

Trust in PLC

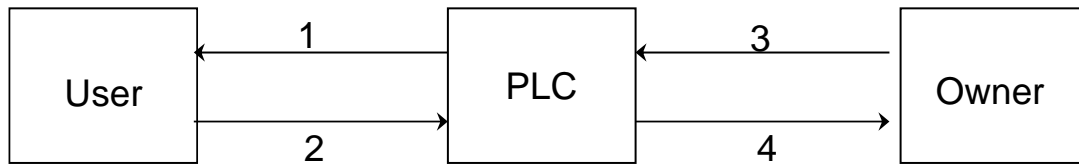

- 1) PLC issues User credentials to access a slice
- 2) Users trusts PLC to create slices on his behalf
- 3) Owner trusts PLC to vet User, track User's network activity
- 4) PLC trusts Owner to keep nodes physically secure and running

Two PLC authorities

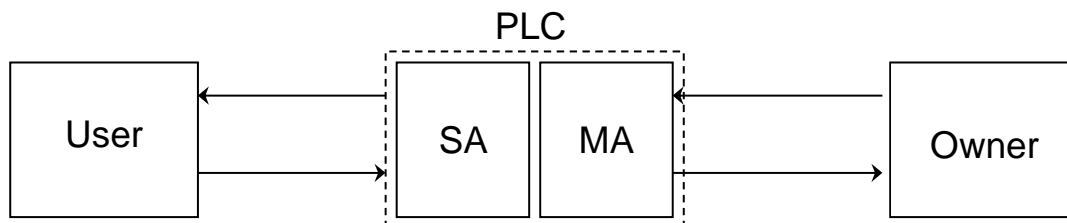

- SA = Slice Authority
- Represents users
 - Names slices

- MA = Management Authority
- Represents owners
 - Creates slices on nodes

Schematic for federation

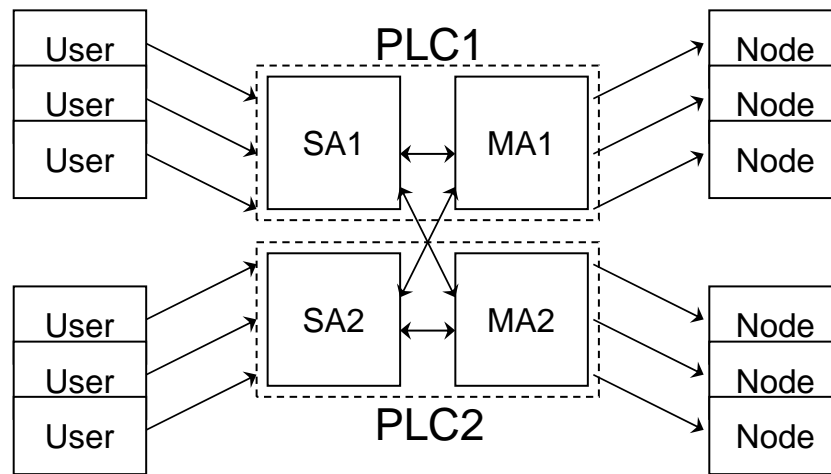

based on slide courtesy of Princeton 17

Implementing federation

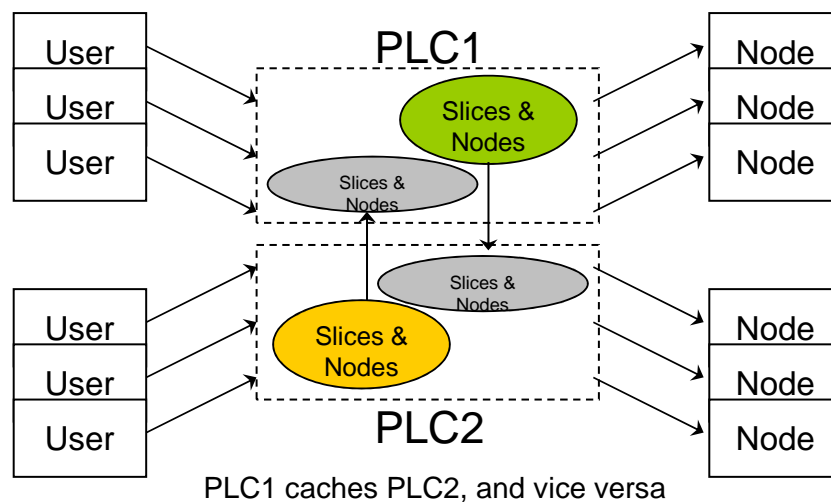

PLC1 caches PLC2, and vice versa

Each user learns of nodes in the other authority

When a node updates, it learns of slice requests from both authorities



based on slide courtesy of Princeton 18

Outline

- OneLab
- Federating PlanetLabs
- Experiences with running a public PlanetLab



19

PLC software: MyPLC

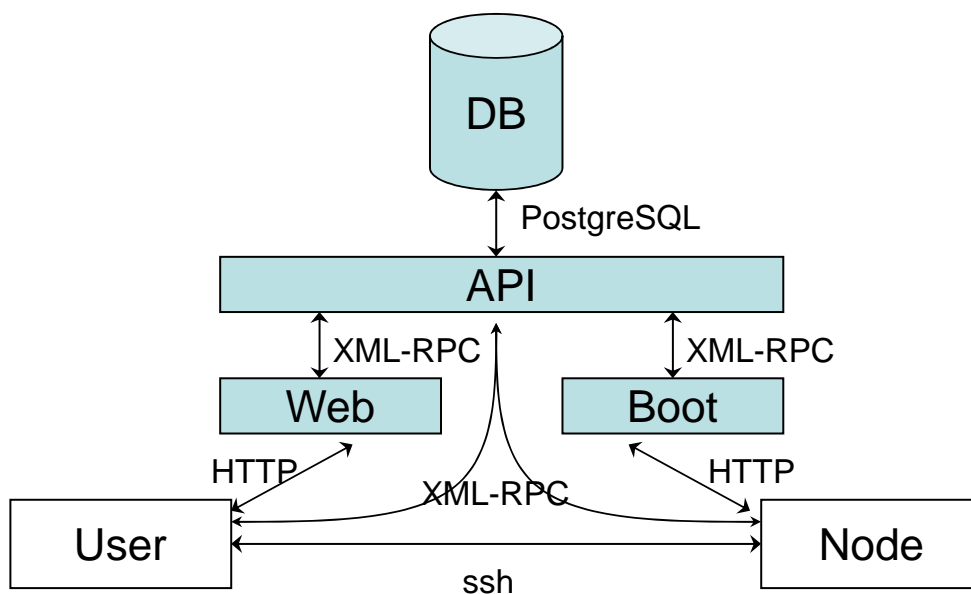

based on diagram by Huang & Parmentelat 20

Additional servers required

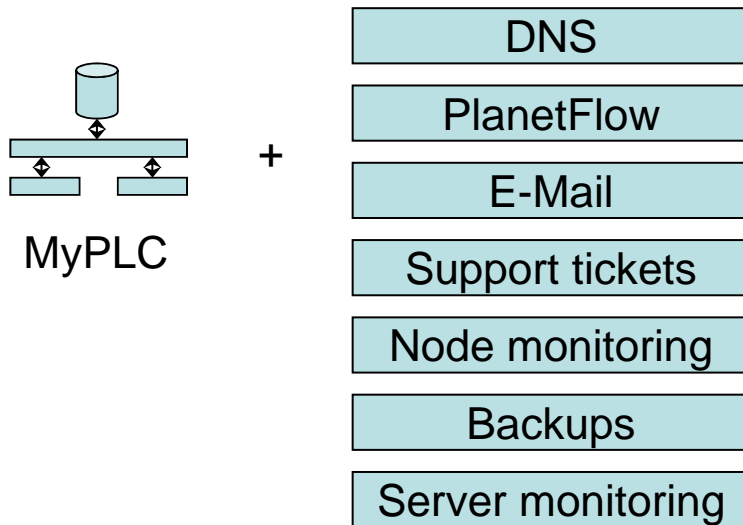

DNS

- BIND for sub-domains
 - www.planet-lab.eu
 - mail.planet-lab.eu
 - monitor.planet-lab.eu
 - etc.
- Load balancing among replicated servers
 - Princeton uses multiple API servers

PlanetFlow

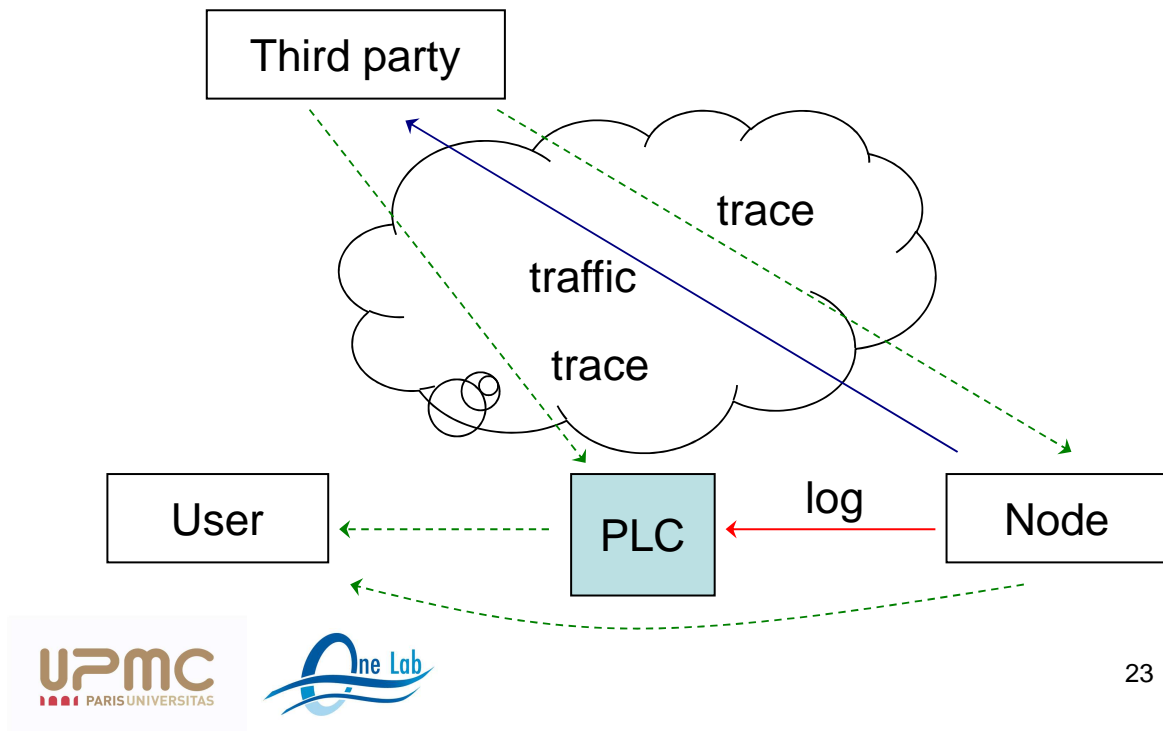

E-mail

Aliases

- support@a-planet-lab.org
 - need anti-spam (e.g., Spam Assassin)
- SLICE@lices.a-planet-lab.org (one for each slice)
- install-msgs@a-planet-lab.org
- etc.

Mailing lists (e.g. Mailman)

- operations@a-planet-lab.org
- etc.

Support tickets

- Receive requests
- Assign to support staff
- Record associated messages and notes
- Ensure timely response

Princeton and UPMC use RT (Request Tracker)



25

Node monitoring

Problems

- Inaccessible?
- Down?
- In debug mode?

Reponses

- Automatic restore
- Notify support team
- Remind node admins

Monitoring scripts are under development at Princeton.



26

Backups

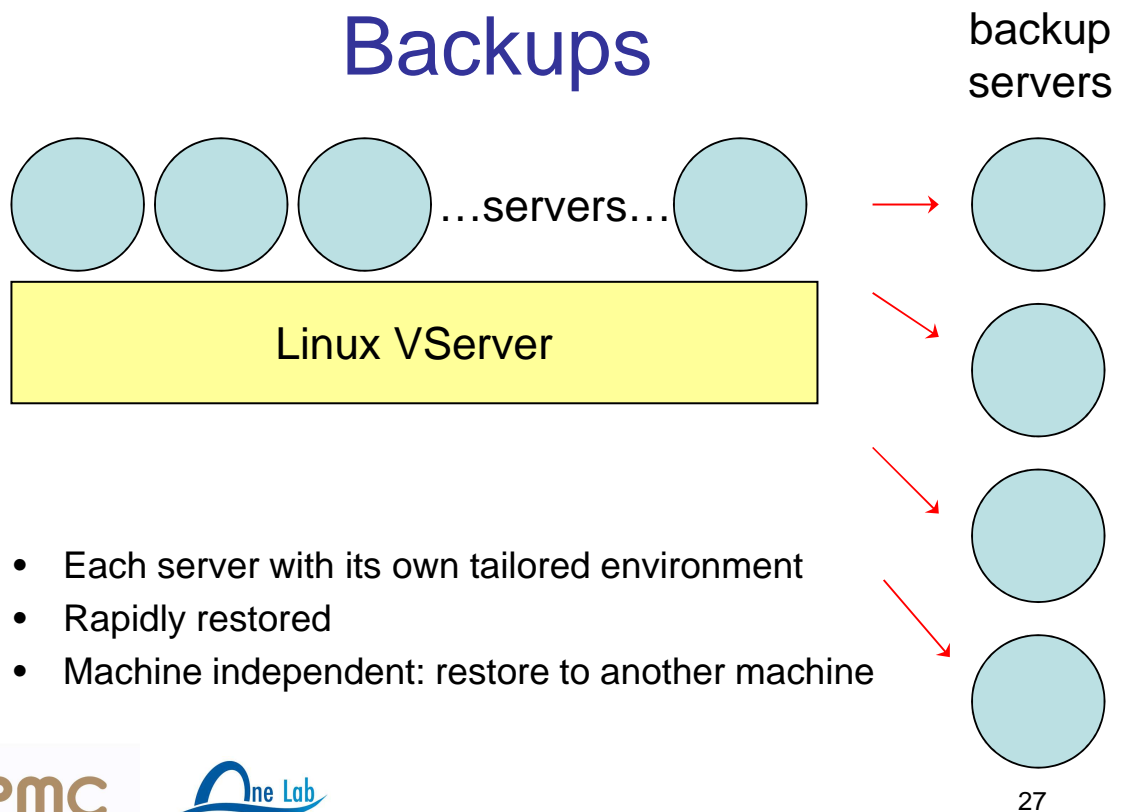

Server monitoring

- Server health
- Running?
- Connected to the outside world?
- Overtaxed? (CPU, memory, bandwidth, disk)

We use a hosted server

- Guarantees: uptime, bandwidth, repair time

We use Ganglia (physical server) + cfengine (services)

Test infrastructure required

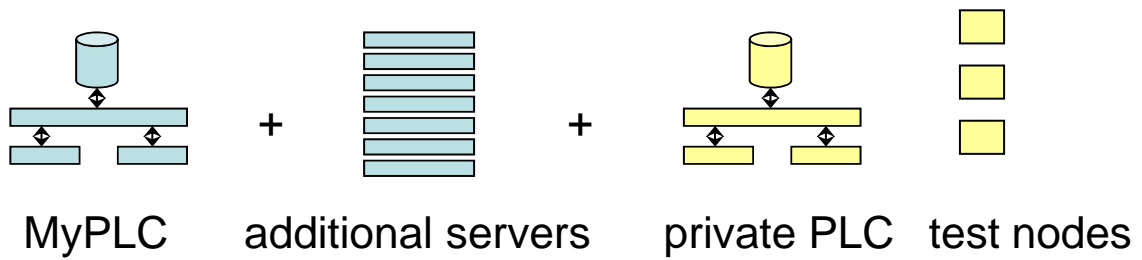

Ensure that a new versions of MyPLC works before rolling it out

Development infrastructure

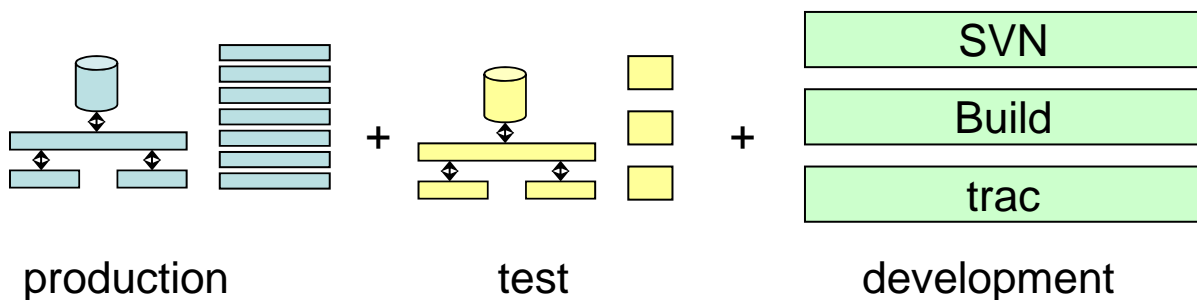

Legal arrangements

- Establish the authority
 - Decide on the form
 - Single institution, consortium, not-for-profit, ...?
 - Set membership policies
 - Who can join, dues, etc.
- Draw up contracts
 - Consortium agreement (if consortium)
 - Membership agreement
 - Acceptable use policy
- Define relationships with other authorities
 - Peers, dependent authorities



31

Staffing

Technical

- Maintain the servers
- Support the members
- Develop the test bed

Administrative

- Legal
- Financial
- Secretarial

Don't forget the science!



32

PlanetLab Europe

<http://www.planet-lab.eu/>

